

nanio series*

Industrial DPSS Lasers

NANIO 1064-16-V-LP

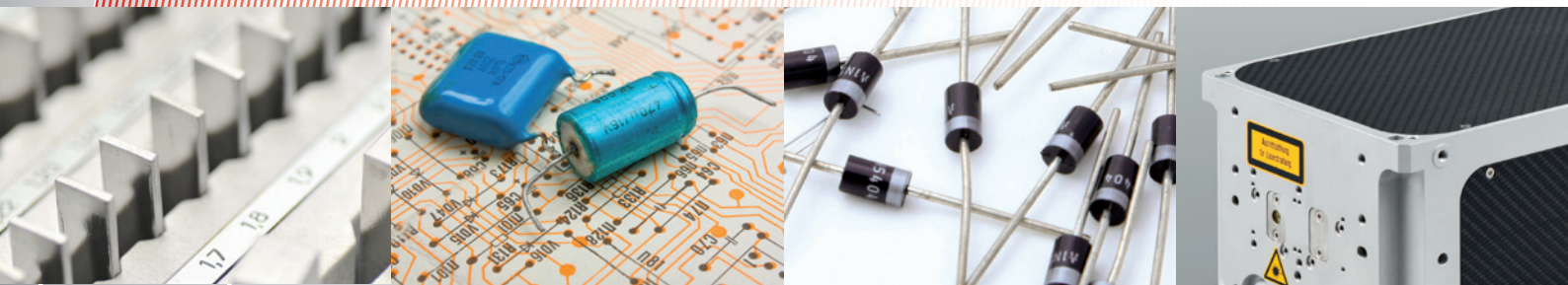

Applications

- * Marking
- * Micromachining
- * Scribing
- * Engraving
- * Solar Cell Manufacturing
- * Semiconductor Manufacturing
- * Drilling
- * Scientific

Features

- * Outstanding performance & reliability
- * Modular industrial design
- * Easy integration and service
- * High average power for high throughput
- * High peak power and short pulse widths
- * Field proven long life pump diode modules
- * Superior pulse-to-pulse stability
- * Optimized performance for your application

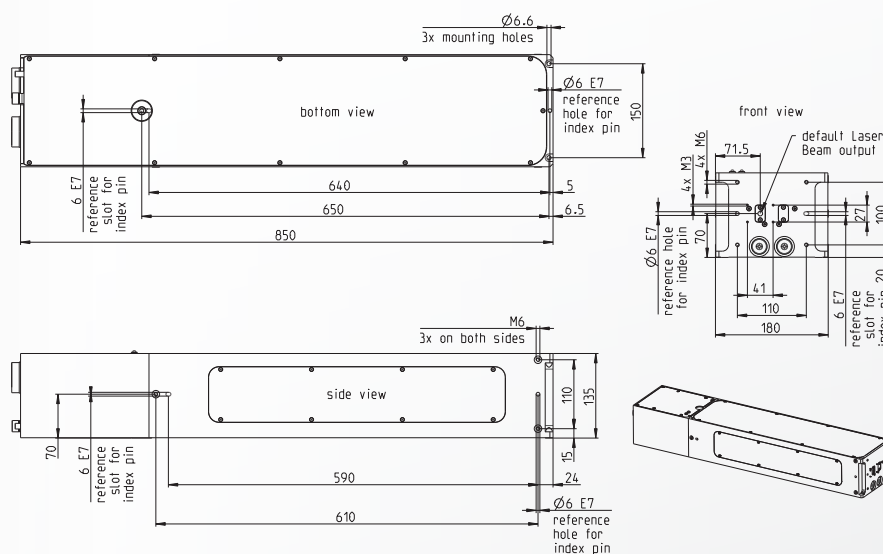

NANIO 1064-16-V-LP

Specifications

Laser Head	Laser Medium	Nd:YVO ₄
	Pump Source	Long Life Pump Diode Modules
	Pulse Unit	Acousto-Optical Q-Switch
Laser Parameters	Wavelength [nm]	1064
	Nominal Power [W]	15 @ 50 kHz
	Repetition Rate [kHz]	Single Shot to 150 kHz
	Polarization	Vertical, 100:1
Beam Parameters	Spatial Mode	TEM ₀₀
	M ²	< 1.2
	Peak Power [kW]	> 20 @ 40 kHz; > 5 @ 100 kHz
	Pulse Energy [μJ]	300 @ 50 kHz
	Pulse Width [ns]	> 100 @ 100 kHz
	Pulse-to-Pulse Stability [rms]	<1.0% @ 50 kHz
	Nominal Beam Diameter at Waist [mm]	1.2
Operating Parameters	Nominal Beam Divergence, Full Angle [mrad]	1.3
	Warm-up Time	< 15 min
	Electrical Connection	115-230 VAC ± 10%, 50-60 Hz, Single Phase
	Laser Power Consumption	500 W
	Cooling	Water-to-Air or Water-to-Water
	Ambient Temperature	15-40 °C (59-104 °F), Non Condensing
Dimensions	Laser Head (L x W x H)	850 x 180 x 135 mm (33.46 x 7.09 x 5.31 in.)
	Power Supply (L x W x H)	500 x 447 x 88.1 mm (19.69 x 17.6 x 3.47 in.) 19" system, 2 RU high
Weights	Laser Head	22 kg (48,5 lbs.)
	Power Supply	12 kg (26.5 lbs.)

Available Options

Umbilical length between laser head and power supply 1-20 m. Standard is 3 m.
 External beam expander box, beam expanders and scan head adapter flanges.
 Customized power supply front design.
 Variable attenuator.

Rev. 1.0, 05/2011

InnoLas follows a policy of continuous product improvement. All specifications are subject to change without notice.
 InnoLas Laser GmbH is DIN EN ISO 9001 certified.

